



Written by Randy Cronk
greatwriting.com

Time and Frequency System Unites GPS Accuracy with Cesium Stability



WHITE PAPER

March 2008

Continuously locked to GPS, the Disciplined 5071A Cesium Oscillator Option is an ultra-precise time and frequency reference that offers the ultimate in stability against environmental effects.

In the world of high-precision time and frequency measurement, GPS is considered the gold standard. According to NIST, using a well-designed receiver it's possible to obtain time from GPS to within an accuracy of 100 ns in a few minutes, and to about ±10 nanoseconds (ns) with a 24 hour average. GPS does, however, present two potential problems as a time and frequency source: 1) GPS signals can be lost; and 2) GPS signals fluctuate due to atmospheric effects. In fact, the most accurate GPS measurements possible require averages of about five days to wash out these moment-to-moment deviations (when the Allan deviation of GPS stability crosses through 5x10⁻¹⁴).

To counteract both these problems, Symmetricom has introduced the Disciplined 5071A Cesium Oscillator Option. Cesium oscillators are well known for being highly stable frequency sources — and the Symmetricom 5071A Cesium Frequency Standard has become an industry leader. The new Option integrates the 5071A with the XLi

Time and Frequency System and its internal GPS receiver option. The XLi produces outputs that include: 1pps, time-of-day and 10MHz, among many others. (See Figure 1.)

The advantages of this GPS/cesium combination are four-fold:

- GPS provides UTC(USNO) referenced time and frequency
- GPS removes the cesium oscillator's frequency offset
- Cesium's high stability smoothes out moment-to-moment GPS signal deviations
- Cesium oscillators offer the industry's best holdover if GPS is lost

In other words, the respective strengths and weaknesses of GPS and the cesium oscillator complement each other. GPS's vulnerability to signal loss and short-term deviations are countered by cesium's excellent long-term stability in the face of environmental factors including loss of GPS. GPS, meanwhile, disciplines the cesium oscillator to the continuously calibrated atomic clocks on the GPS satellites, and minimizes the long term frequency offset. Achieving the best performance — medium and long-term — requires the new XLi Option to optimally

exploit the combined frequency stability characteristics of the GPS system and the 5071A.

How It Works

The Disciplined 5071A Cesium Oscillator Option consists of two key modules:

- An XLi Time and Frequency System with special firmware, the GPS receiver and cesium disciplining option module
- A 5071A Cesium Primary Frequency Standard (customers with a 5071A can order the XLi alone)

The 5071A includes an ultra-fine resolution digital synthesizer, a high quality ovenized 10 MHz crystal oscillator, and a beam tube of cesium atoms excited to a known resonance. In response to the cesium resonance, the synthesizer makes fine frequency adjustments in precisely controlled increments to the crystal oscillator's outputs. In summary, the Option functions as follows:

The XLi uses the 5071A as its primary oscillator, continuously measuring and steering (disciplining) it into frequency phase lock with GPS-derived UTC(USNO) time.

The XLi provides optimal time and frequency performance when locked to four or more satellites. A digital phase lock loop implemented in the microprocessor of the XLi steers the 5071A in response to GPS.

When a complete satellite outage occurs, the XLi uses the 5071A oscillator as its frequency reference. During these periods, the rate at which the XLi time and frequency outputs diverge from UTC is governed by two parameters:

1. The 5071A frequency offset
2. The ambient temperature change during the outage period and the temperature coefficient of the oscillator's output frequency

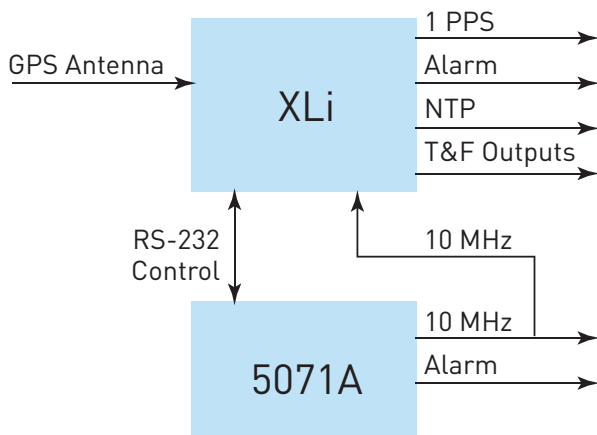

FIG 1 GPS disciplines the cesium 5071A 10MHz master clock within the XLi Time and Frequency System.

Parameter 2 is a function of the cesium oscillator and the temperature characteristics of the environment in which the XLi is operated. The first parameter is determined by the stability of the GPS system and the control parameters chosen in the XLi's digital phase lock loop. Proprietary algorithms perform multi-satellite averaging and detect and remove data outliers — so as to apply the optimally stable steering command to the oscillator. The algorithms implement a Type III servo on the phase relationship between the oscillator and UTC. The output of the control algorithm — a floating-point number between $+2.0748035 \times 10^{-10}$ and $2.0748668 \times 10^{-10}$ — is transmitted over a dedicated RS-232 port to the 5071A as its steering command.

Smarter Steering

Figure 2. USNO tests of the XLi SAASM 5071 Disciplining Option show root mean square deviations of less than 4ns over 10 days and a cumulative offset of zero.

Even if GPS is never lost, users will obviously still want to benefit from both GPS's long-term stability and cesium's insensitivity to environmentally induced instability — such as temperature-induced oscillator frequency shifts. For example, operating the 5071A Primary Frequency Standard over the full 0°C to $+50^{\circ}\text{C}$ ambient temperature range results in a very small degradation in the stability $\pm 2 \times 10^{-15}/^{\circ}\text{C}$. In the absence of GPS over the long-term, however, time offsets will develop that would be a problem for high performance timing applications.

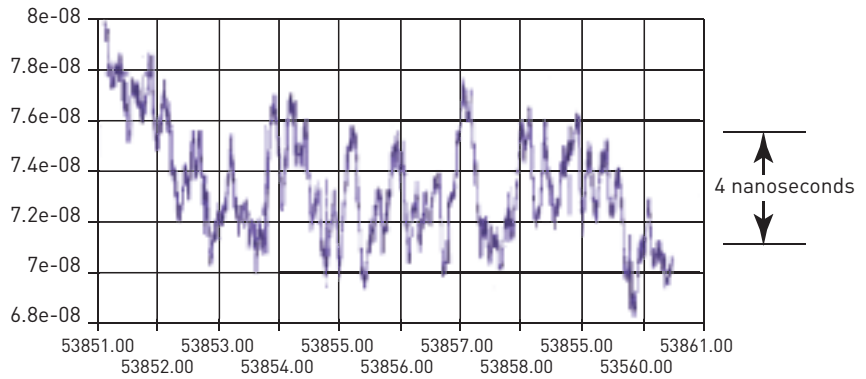

FIG 2 USNO tests of the XLi SAASM 5071 Disciplining Option show root mean square deviations of less than 4ns over 10 days and a cumulative offset of zero.

The key is to choose time constraints in the steering algorithm that reflect the relative frequency stability characteristics of the GPS system and the 5071A. Although cesium oscillators are extremely stable (narrow moment-to-moment deviations), over the long term, time errors due to an oscillator's fractional frequency offset (the cumulative error of its deviations) will grow. And although GPS's moment-to-moment deviations are much wider due to atmospheric effects, their cumulative error is virtually zero. The atomic clocks in the GPS satellites are corrected at least once every day to the USNO master clock. Given a sufficiently long time sampling period (τ), GPS values ultimately average to a time and frequency that is extremely accurate and the 5071A fractional frequency offset is minimized.

The Allan Deviation stability of the GPS system crosses through 5×10^{-14} at a τ of ≈ 5 days — the point at which average sampling error is as close to zero as it will come. Since the Allan Deviation floor of the 5071A is also $\approx 5 \times 10^{-14}$, the control loop parameters are set to ultimately reach an equivalent averaging time of five days. The result is a time and frequency reference that is both extremely stable and highly accurate medium to long term. As shown in Figure 2, root mean square deviations fall within a 4ns band over 10 days, which is or ± 2 ns relative to the United States Naval Observatory Master Clock. This is while the GPS is disciplining the cesium oscillator to a SAASM reference. And if the XLi were to lose GPS, holdover accuracy is still maintained to $< 1 \times 10^{-13}$ ($\pm 2 \times 10^{-15}/^{\circ}\text{C}$). That's good news for high-performance time and frequency users looking to unite GPS accuracy with cesium's environmental stability in a convenient package.



SYMMETRICOM, INC.
 2300 Orchard Parkway
 San Jose, California
 95131-1017
 tel: 408.433.0910
 fax: 408.428.7896
 info@symmetricom.com
 www.symmetricom.com